

Simple. Pressureless. Accumulation. Buffering. Line Control.

Keeping your product moving demands intelligent conveyance. Hartness' Model 6900 DYNAC is a simply innovative solution that is designed to bring dramatic improvement to packaging line performance. The Model 6900 single-file DYNAC provides FIFO accumulation, pressureless product handling, as well as unique line balancing characteristics for a variety of rigid and flexible container types. DYNAC has the unique ability to automatically expand its usable length based on line condition. Frequent slowdowns and "micro-stops" that are inherent, even in the best designed lines, can dramatically reduce throughput and efficiency. DYNAC virtually eliminates the effect of these occurrences, raising productivity by providing a constant and optimal product flow from machine to machine.

The 6900 DYNAC's space-saving spiral configuration enables the implementation of Hartness' industry-leading, DYNAC-centric line concept. DYNAC-centric lines eliminate complicated controls and allow for close-coupling of machine centers. Close-coupling of machines can result in packaging lines with a smaller footprint, that require fewer operators and that consume fewer utilities than traditional packaging line designs.

Because DYNAC virtually eliminates container to container contact, DYNAC-centric lines operate with minimal noise.

The Model 6900 DYNAC is exceptionally versatile. The system handles a wide range of product shape, size and material. The DYNAC handles a variety of packaging formats including plastic, glass, and paperboard. DYNAC is also adept at conveying and accumulating flexible packaging such as pouches. Light-weighted and reverse-tapered containers which are sensitive to line pressure are easily conveyed through the DYNAC. Doesn't your line deserve one?



Benefits

- / Increased line efficiency
 - Balances container flow between machine centers
 - Reduces line pressure (eliminates micro-stops)
- / Provides perfectly metered products downstream regardless of upstream output
- / Sequential first-in/ first-out accumulation
- / Improved product quality
 - Reduced breakage and label damage
 - Zero pressure
 - Reduces line lubrication
- / DYNAC-centric line design
 - Elimination of complicated line controls
 - Allows for smaller footprint
- / Flexible operation
 - Wide product range
 - Wide speed range
 - Simple changeover
- / Reduced labor needs
 - Low maintenance
 - Allows close-coupling of line components for shared operators and small footprint
- / Bypass function allows for maintenance on the system during line operation
- / Variety of machine sizes available

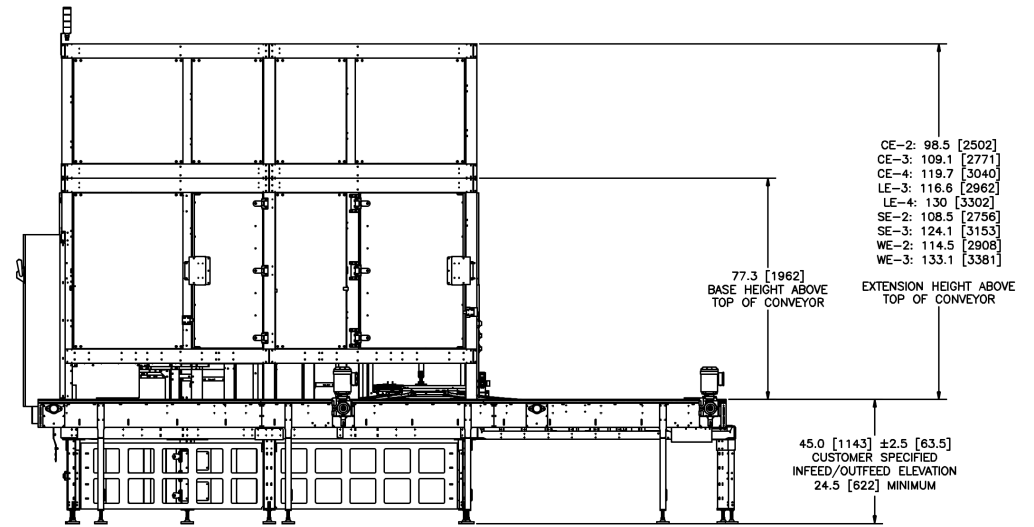
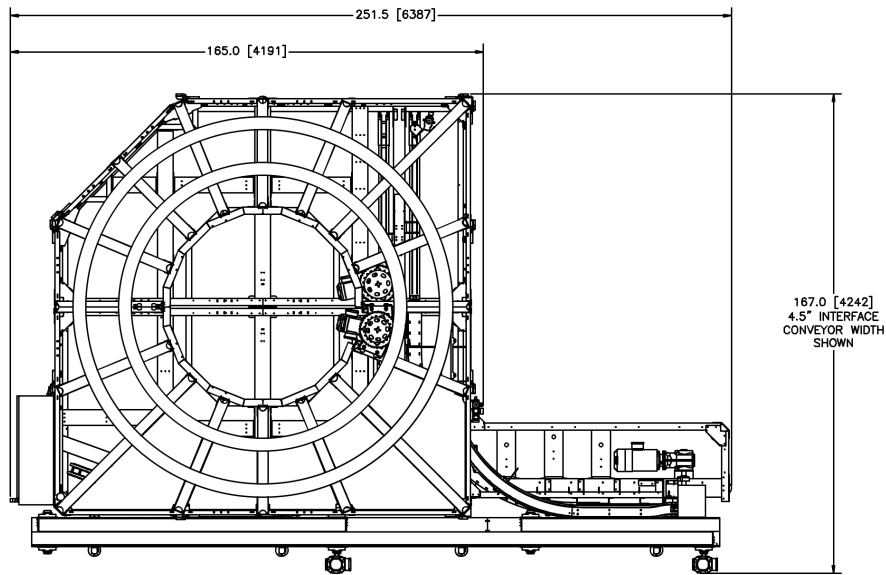

MODEL 6900	C	L	S	W
Maximum Package Height	6.75" 171mm	9.25" 234mm	11.75" 298mm	14.75" 374mm
Maximum Package Width	7" 178mm	7" 178mm	7" 178mm	7" 178mm
Accumulation Range	264 - 616 ft 80 - 188 m	205 - 498 ft 63 - 152 m	205 - 381 ft 63 - 116 m	205 - 381 ft 63 - 116 m

The dimensions, descriptions, illustrations and other particulars in this profile are given in good faith but are not intended to and do not constitute any guarantee or warranty given by Hartness International or form any part of any contract. Photographs and/or illustrations may be shown with optional equipment or without safety guards in order to show features. Hartness International designs are covered by numerous US and International Patents.



500 Hartness Drive
Greenville, SC 29615 USA
phone: 864.297.1200 / fax: 864.297.4486
email: info@hartness.com / www.hartness.com